

MEASUREMENT OF GAIN COMPRESSION IN SIS MIXER RECEIVERS

A. R. Kerr¹, J. Effland¹, S.-K. Pan¹, G. Lauria¹,
A. W. Lichtenberger² and R. Groves¹

¹National Radio Astronomy Observatory*
Charlottesville, VA 22903

²University of Virginia
Charlottesville, VA 22904

ABSTRACT

When an SIS mixer is partially saturated by broadband noise, it continues to exhibit a linear response to a small CW test signal, with the small-signal gain depending on the level of the saturating noise. This allows the CW test signal to be used as an indicator of the receiver gain in the presence of high-level noise. If not taken into account, gain compression can be a significant factor limiting the accuracy of high precision radio astronomy instruments.

Keywords: Superconductor-Insulator-Superconductor mixers, saturation, gain compression, dynamic range

INTRODUCTION

The Atacama Large Millimeter Array (ALMA) is striving to achieve an absolute flux measurement accuracy of 1%. Plambeck [1] has pointed out that gain compression (saturation) in SIS mixer receivers is likely to be a significant factor limiting the measurement accuracy. In this paper, we report measurements of the saturation of an SIS receiver in the 230 GHz band and show that in this band the thermal noise from a room temperature black body source is sufficient to produce $\sim 1\%$ gain compression in a mixer with four junctions in series.

At the 2002 Space Terahertz Technology Symposium we described a method for calculating the gain compression in an SIS mixer with a broadband noise input [2]. It was noted that, even when partially saturated by a high-level noise signal, the response of an SIS mixer to a small CW test signal is linear, the small-signal gain depending on the level of the saturating noise signal. This allows the CW test signal to be used as an indicator of the receiver gain in the presence of high-level signals.

*The National Radio Astronomy Observatory is a facility of the National Science Foundation operated under cooperative agreement by Associated Universities, Inc.

MEASUREMENT PROCEDURE

The gain compression measurements described here were made on a mixer-preamplifier for ALMA Band 6 (211-275 GHz) [3] with an intermediate frequency of 4-12 GHz. The measurement setup is shown in Fig. 1. A small CW test signal is introduced through the LO waveguide while the receiver input is switched between liquid nitrogen and room temperature sources using the chopper wheel. (The 20 dB cold pad between the mixer-preamp and the IF switch allows similar signal levels to be maintained throughout the IF system when measuring the mixer-preamplifier and when measuring the gain and noise temperature of the IF system using the hot and cold IF loads in the Dewar.)

The RF test signal is adjusted to give an IF power output power P_{HS} 10-20 dB above the output noise power P_H with only the hot load at the receiver input. With the cold load at the input, the IF power levels with the test signal on and off are P_{CS} and P_C . The output power due to the test signal alone is $(P_{HS} - P_H)$ with the hot load at the input and $(P_{CS} - P_C)$ with the cold load. If it is assumed that the receiver is not significantly saturated when connected to the cold load, it follows that the percentage gain compression due to the hot load is given by

$$C = 100 \times \left(1 - \frac{P_{HS} - P_H}{P_{CS} - P_C} \right) \text{ percent.} \quad (1)$$

The mixer-preamp may not be the only contributor to saturation; in fact, it is likely that the IF amplifier chain will have some degree of gain compression. This can be particularly important when the full IF bandwidth is large compared with the bandwidth of the final filter before the power meter. If the percentage gain compression of the mixer-preamp is C_1 and that of the rest of the IF chain is C_2 , then the percentage gain compression for the whole

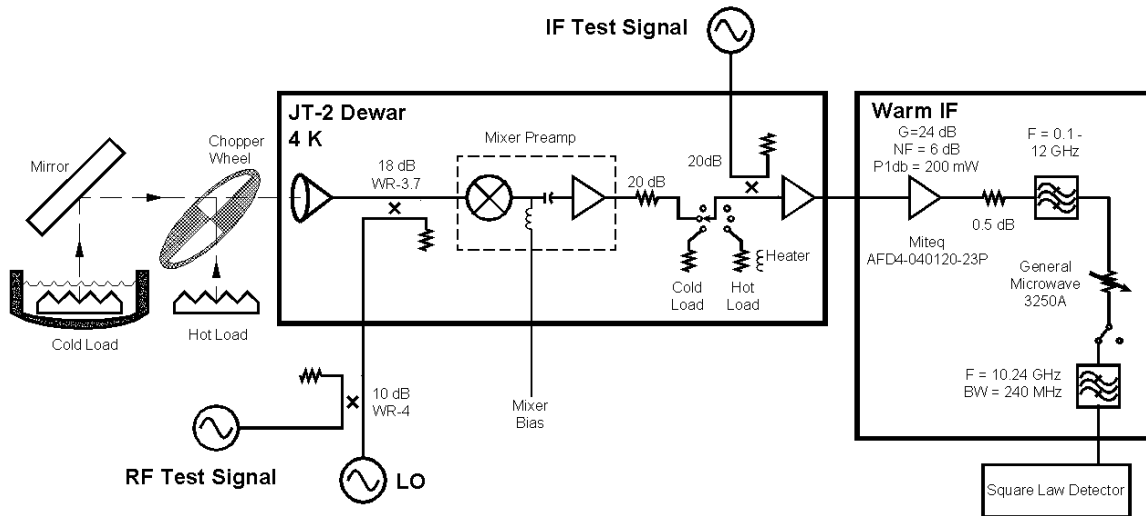

Fig. 1. Setup for measuring gain compression.

receiver is, to first order, $C = (C_1 + C_2)$. To measure the gain compression of the amplifier stages following the mixer-preamp under test, a small IF test signal can be introduced through the directional coupler following the IF switch in Fig. 1. In measuring C_2 , it is important not only to ensure that the IF input (noise) power is the same as when C is measured for the whole receiver, but also that the input noise spectrum has the same shape.

MEASUREMENTS

Figure 2 shows the data from a typical saturation measurement. The SIS mixer has four junctions in series and the LO frequency is 230 GHz. The percentage saturation is seen to vary almost sinusoidally with a period of ~ 8 minutes. When liquid nitrogen was added to the cold load, a change of phase was observed in the ripple, indicating that it is caused by the reflection of the test signal at the surface of the LN_2 . LO power emerging from the receiver is also reflected at the LN_2 surface, but the magnitude of the LO reflection, indicated by the modulation of the DC mixer current, is insufficient to contribute significantly to the measured gain variation. To check that the CW test signal does not itself cause significant saturation, its level was changed by ~ 4 dB during each measurement and no significant change was observed in the results.

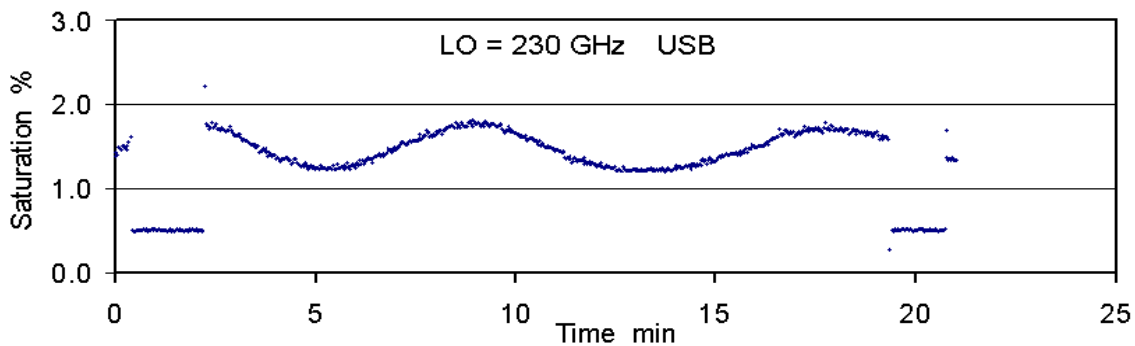

Fig. 2. Gain compression (saturation) data as a function of time, measured on a four-junction SIS mixer-preamp with the LO at 230 GHz and the small test signal in the upper sideband. The sinusoidal ripple is caused by reflection of the test signal at the surface of the LN_2 in the cold load as it boils away. The horizontal end segments at 0.5% indicate the degree of gain compression in the IF stages following the mixer-preamp.

Saturation in the IF amplifiers following the mixer-preamp was measured with exactly the same setup used to measure the overall receiver saturation, except that the test signal is now injected at the IF through the 20 dB coupler in the Dewar, shown in Fig. 1. The RF hot and cold loads are connected at the receiver input as before, thus ensuring that the IF amplifiers see the same noise power and spectral characteristics as in the overall saturation measurement. The results of this measurement are shown in the end segments of the data in Fig. 2 and indicate that $\sim 0.5\%$ saturation is due to the IF amplifiers following the mixer-preamplifier.

DISCUSSION

Large-Signal Gain Compression and Incremental Gain Compression

Fig. 3 shows the output power of a receiver with gain compression at higher input powers, as a function of the receiver input power. With zero input power, the output power from the receiver is $G_0 P_{Rx}$, where G_0 is the receiver gain at low input power and P_{Rx} is the equivalent input noise power of the receiver. P_H represents the input power from a hot noise source sufficient to cause some degree of gain compression and produce an output power $G_{LS}(P_H + P_{Rx})$, which is lower than the output power $G_0(P_H + P_{Rx})$ which would be produced in the absence of any gain compression. $G_{LS}(P_{in})$ is the large-signal gain of the receiver. The incremental gain $G_{inc}(P_{in})$ is the slope dP_{out}/dP_{in} of the gain curve. At low input powers, $G_{LS} = G_{inc} = G_0$. The incremental and large-signal gains are related by

$$G_{inc} = \frac{dP_{out}}{dP_{in}} = \frac{d(G_{LS} P_{in})}{dP_{in}} \quad (2)$$

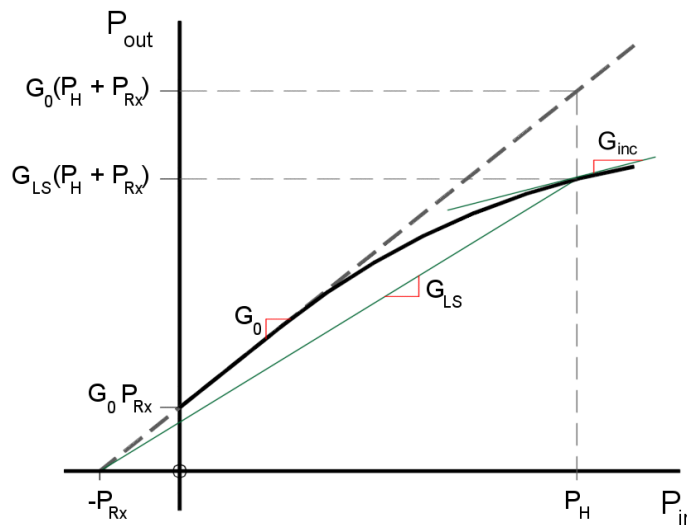

Fig. 3. Receiver gain curve, P_{out} vs P_{in} , showing large signal gain G_{LS} and the incremental gain $G_{inc} = dP_{out}/dP_{in}$. The quantity P_{Rx} is the equivalent input noise power of the receiver.

Our earlier analysis [3] of gain compression was concerned with the large-signal gain compression, which is difficult to measure at low levels. In the present work, we have described a simple method for measuring the incremental gain compression. The large-signal gain compression can be related to the incremental gain compression using equation (13) of [2] which gives the large signal gain as a function of the normalized RMS noise input voltage S_{in} :

$$G_{LS} = G_0 \frac{1}{\sqrt{2\pi} C_3^2 S_{in}^3} \int_{-\infty}^{\infty} \arctan^2(C_3 V_{in}) \exp\left(-\frac{V_{in}^2}{2S_{in}^2}\right) dV_{in}, \quad (3)$$

where $S_{in}^2 = \left(\frac{e}{Nh\nu}\right)^2 G_0 P_{sig} R_L$, $C_3 = 3.3$ is a constant for all SIS mixers, P_{sig} is the signal input noise power, and R_L is the IF load resistance seen by the SIS mixer. From this, the incremental gain is determined using (2).

Figure 4 shows the large-signal and incremental gain compression plotted together as functions of S_{in}^2 . Using Fig. 4, it is possible to deduce the large-signal gain compression from the (measured) incremental gain compression, and thereby to apply an appropriate correction to a receiver gain calibration made using hot and cold loads. Referring to Fig. 3, the output power measured with the hot load in front of the receiver $G_{LS}(P_H + P_{Rx})$ can be corrected to give the output power $G_0(P_H + P_{Rx})$ which would be measured if the receiver had no gain compression. For the mixer-preamplifier gain compression measurement shown in Fig. 2, the incremental gain compression is 1% (after correcting for the 0.5% compression in the following IF amplifiers). From Fig. 4, the corresponding value of S^2 is 0.00025, and the large-signal gain compression is 0.5%.

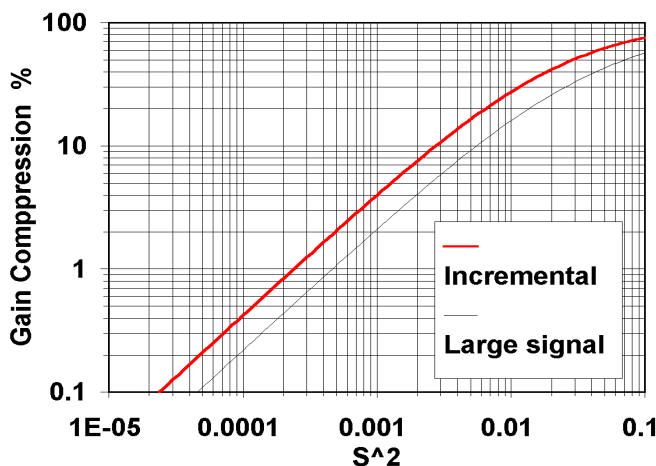

Fig. 4. Incremental and large-signal gain compression as functions of the normalized signal input noise power S^2 . These universal curves apply to all SIS mixers.

Agreement with Earlier Work

Figure 4 can also be used to deduce the incremental gain compression of a mixer whose large-signal gain compression has been estimated as described in [2]. Fig. 5 (from [2]) shows the large-signal gain compression produced, in a 230 GHz SIS mixer with N junctions in series, by a room temperature source, as a function of the single-sideband mixer gain,

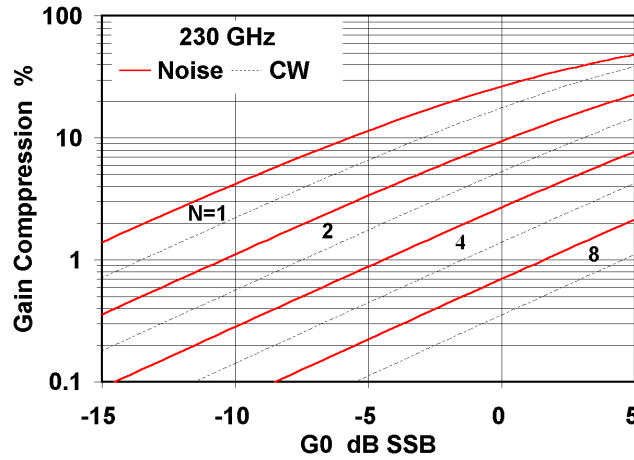

Fig. 5. Gain compression produced by noise from a room temperature source in an SIS mixer with N junctions in series, under the assumptions listed in the text. (From [2].)

under the following assumptions: (i) the input noise bandwidth B_1 in each sideband is equal to 20% of the LO frequency, (ii) the IF load impedance is 50 ohms over the extended IF band $0 < f_{IF} < B_1$, and (iii) the small-signal gain is constant over $0.8 f_{LO} < f_{sig} < 1.2 f_{LO}$. We were not able to measure the gain of the mixer used in these measurements because it was integrated with the preamplifier but, based on experience with similar mixers without integrated preamplifiers, we estimate the (SSB) mixer gain to be in the range -3 to -7 dB. Under the above assumptions, Fig. 5 indicates a large-signal gain compression of 0.6% to 1.5% when the receiver is connected to a room temperature source. This is slightly higher than the 0.5% large-signal gain compression deduced using Fig. 4 from the measured incremental gain compression — a discrepancy not surprising given the uncertainty of assumptions (i) - (iii) used in the theoretical calculation.

Post-Mixer Noise Contribution

In the present discussion, it has been assumed that all the noise power at the receiver output originates in or before the mixer, and thereby contributes to the saturation of the mixer. In fact, noise originating in the IF preamplifier and subsequent amplifiers does not appear at the output of the mixer and therefore does not contribute to saturation of the mixer. In most practical cases this will cause little error in the gain compression analysis – the noise contribution of the IF amplifier being far less than that required to cause significant gain compression (*e.g.*, a room temperature source). However, in a few unusual cases, *e.g.*, if the mixer saturates at a very low input power, or the IF preamplifier is very noisy, it could be necessary to separate the noise of the IF stages from that of the mixer and source in analyzing the saturation.

Square-Law Detector vs Power Meter

Our initial measurements of saturation were made using an IF power meter with the RF chopper wheel running slowly (several seconds in each position), but gain drift in the room temperature IF amplifiers made consistent measurements difficult to obtain. The power sensor was replaced by a tunnel diode detector and the chopper run at ~ 10 revolutions per second (~ 20 Hz chopping rate); then the drift was much less significant.

Square-Law Detector vs Spectrum Analyzer

If a spectrum analyzer is used instead of a square-law detector (or power meter), caution may be necessary in estimating the quantities $(P_{HS} - P_H)$ and $(P_{CS} - P_C)$. This is because most modern spectrum analyzers use an envelope detector as opposed to a square-law detector, and the indicated signal power in the presence of noise is not simply the sum of the signal and noise powers. If envelope detection is used with the usual log display, the correction factor is $-10.42 \times 10^{-0.333(H(\text{dB}))}$ dB, where H is the indicated signal-to-noise ratio [4]. This is shown in the upper curve of Fig. 6.

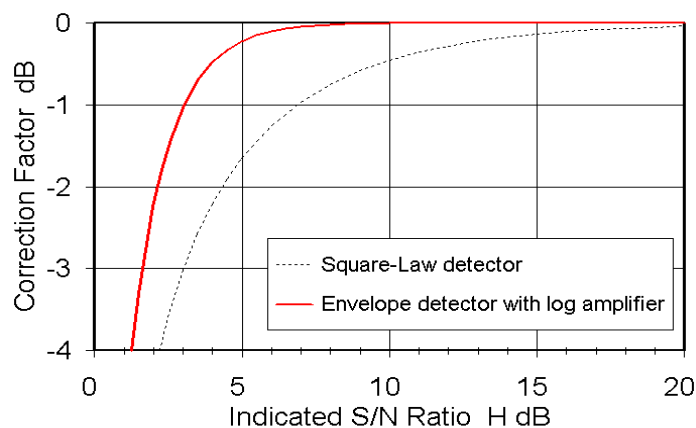

Fig. 6. Correction for system noise when measuring a CW test signal. The correction factor is plotted as a function of the indicated signal-to-noise ratio H . The upper curve applies to measurements using a spectrum analyzer with an envelope detector (usual in modern spectrum analyzers) and a log (dB) display. The lower curve is for measurements using a power meter with a square-law detector. From [5].

Source Mismatch

A possible source of error in measuring gain compression occurs if LO reflections from the hot and cold loads are sufficient to modulate the mixer gain at the chopper frequency. The mixer bias current is a good indication of the LO level at the mixer. Separate measurements can be made of the receiver gain and mixer current as functions of LO power, and the resulting gain vs mixer current curve allows the degree of gain modulation due to

chopper modulation of the LO power to be estimated. This was not significant in the present measurements.

REFERENCES

- [1] R. L. Plambeck, "Receiver amplitude calibration for ALMA," ALMA Memo 321, August 27, 2000. (<http://www.alma.nrao.edu/memos/>)
- [2] A. R. Kerr, "Saturation by noise and CW signals in SIS mixers," *Proc. 13th Int. Symp. on Space Terahertz Tech.*, Harvard Univ., pp. 11-22, 26-28 March 2002. (<http://www.alma.nrao.edu/memos/>)
- [3] E. F. Lauria, A. R. Kerr, M. W. Pospieszalski, S.-K. Pan, J. E. Effland, A. W. Lichtenberger, "A 200-300 GHz SIS mixer-preamplifier with 8 GHz IF bandwidth," *2001 IEEE International Microwave Symposium Digest*, pp. 1645-1648, May 2001. (<http://www.alma.nrao.edu/memos/>)
- [4] A. A. Moulthrop and M. S. Muha, "Accurate measurement of signals close to the noise floor on a spectrum analyzer," *IEEE Trans. Microwave Theory Tech.*, vol. 39, no. 11, pp.1182-1885, November 1991.
- [5] A. R. Kerr, S.-K. Pan and J. E. Effland, "Sideband calibration of millimeter-wave receivers," ALMA Memo 357, 27 March 2001. (<http://www.alma.nrao.edu/memos/>)