

## Radiation from a Quasioptical Josephson Junction Array

Michael J. Wengler and Boran Guan  
*Electrical Engineering Department, University of Rochester, NY 14627*

Elie K. Track  
*HYPRES Inc., 175 Clearbrook Rd., Elmsford NY 10523*

### Abstract

At 190 GHz, 0.36  $\mu$ W has been detected from an  $11 \times 58$  array of niobium Josephson junctions. The power is radiated directly into free space above the surface of the two-dimensional array of junctions. Detection is made by a commercial bolometer outside the array cryostat. The junctions in the array are closely spaced in the  $y$ -dimension, but spaced by more than one-half wavelength in the  $x$ -direction. This asymmetry results in mutual phase-locking between adjacent junctions suitable for the production of  $y$ -polarized radiation. The resonance and asymmetry also result in a reasonable impedance match between the Josephson junctions and the free-space radiation mode.

### Introduction

Large two-dimensional arrays of Josephson junctions were proposed as submillimeter wavelength oscillators because of some attractive properties[1]. Large two-dimensional arrays have been successfully demonstrated with semiconducting devices for a variety of microwave applications[2-5]. In this context, large means the overall dimensions of the arrays are larger than a wavelength of the radiation.

The arrays proposed[1] have a number of properties useful for power combing applications. First, the impedance they present to the attached device can be controlled by their design. Second, they allow the coherent addition of power from many devices in the array so that arrays can handle or provide orders of magnitude more power than single devices. Finally, because they are large compared to a wavelength, they couple radiation directly into a free-space mode propagating normal to the array. Because of this last property, we refer to the Josephson junction array described here as a Quasioptical Josephson Oscillator, or QJO.

Our main goals in pursuing two-dimensional arrays are the possibility of higher radiated power from a larger number of junctions, and the possibility of higher frequency operation. In a one-dimensional array, radiation must travel through an increasing length of microstrip line as more junctions are added to the array. Both superconducting and normal metal microstrip lines have loss which increases as operation frequency is raised. In the QJO, however, generated radiation does not propagate any significant distance through on-chip wiring. Instead, it goes into a free-space mode propagating away from the array. If the QJO is extended by adding more junctions, it has a larger area from which its total power is radiated. It is not necessary for the added junctions' radiation to propagate through the longer lengths of wires on the extended QJO.

We have detected power from a number of fabricated arrays. The largest power detected is 0.36  $\mu$ W at a frequency of 190 GHz from an array of 638 junctions. The superconducting oscillator chip is in one liquid helium cryostat, and the bolometer we use for power detection is in another. The free-space radiation power we observe is uncorrected for any loss or beam dilution as it travels through a quartz lens, vacuum windows, and a few cm of air between the two cryostats.

This paper describes our work on these arrays. We recently reported the detection of significant power from these arrays. It is only the third time that near- $\mu$ W power levels of Josephson junction radiation propagating in free space have been observed. Martens *et al.* observed close to 1  $\mu$ W at 110 GHz from their largest symmetric array[6]. Booi and Benz observed 0.2  $\mu$ W from 53 to 230 GHz from a small symmetric array that couples to a stripline circuit which is then coupled to a waveguide radiator[7]. Higher output powers of tens of  $\mu$ W at

frequencies near 500 GHz have been reported from one-dimensional Josephson arrays, but all of that power was dumped directly from the microstrip generator into an on-chip resistor[8].

### QJO Particulars

A simplified schematic of our most successful QJO array is shown in Fig. 1. It is a variation of the array originally proposed by Wengler *et al.*[1]. The QJO tested had 11 columns of 58 junctions each for a total of 638 junctions. Junctions are spaced by  $260\ \mu\text{m}$  horizontally, but by only  $56\ \mu\text{m}$  vertically. This gives the array an active area of  $2.86 \times 3.25\ \text{mm}$  or about  $1.8 \times 2.0\ \lambda_0$  where  $\lambda_0$  is the free-space wavelength at the oscillation frequency.

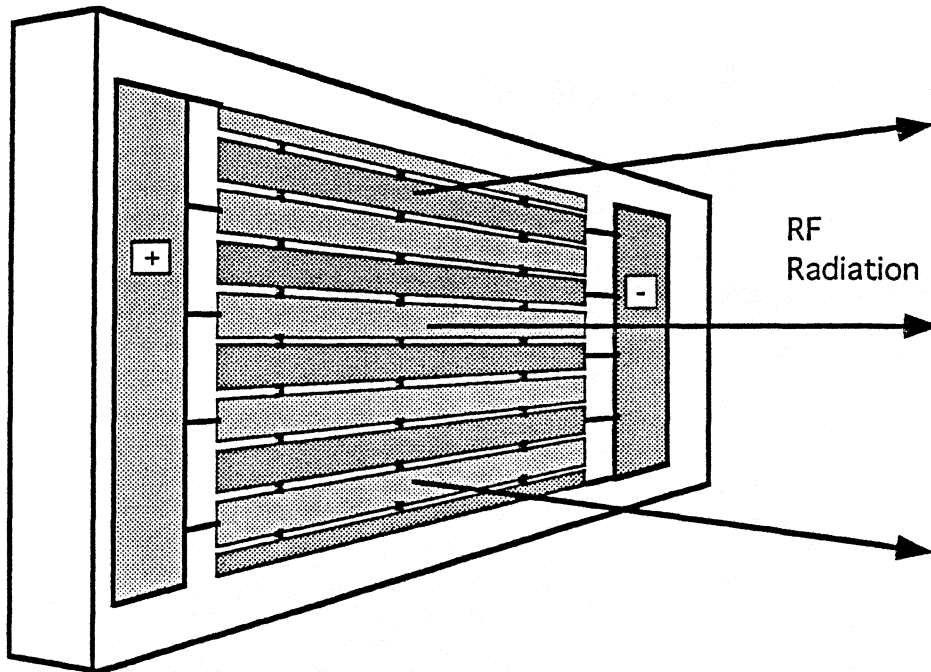

Figure 1. The figure illustrates an array with only 27 Josephson junctions. The array reported here has 638 junctions in it. However, the basic circuit idea is the same as shown in this figure.

Dc connections are made to alternating rows, from the sides, so that all junctions in the QJO are dc biased in parallel. All wires in the circuit are superconductors. In operation, every junction in the array sees *exactly* the same dc bias voltage, so that the Josephson frequency of oscillation of each junction,  $f_J = 2eV_0/h$ , is *exactly* the same. However, it is not necessarily the case that all junctions will oscillate in the same phase: this result must be brought about through circuit design, as described below.

A micrograph of the fabricated array in the vicinity of two of the SIS's is shown in Fig. 2a. The large white band crossing the picture is one of the +DC biased lines shown in Fig. 1. The edges of two -DC biased lines are seen in gray at the top and bottom of the micrograph. The Josephson junctions are Nb/Al<sub>2</sub>O<sub>3</sub>/Nb Superconductor-Insulator-Superconductor (SIS) tunnel diodes, shunted by resistors. The two SIS's in Fig. 2 are under the small dots which are seen in the two gaps between the + and -DC bias lines. The visible small feature is actually a  $2 \times 2\ \mu\text{m}$  square via hole to allow contact to the top of the  $3 \times 3\ \mu\text{m}$  SIS. We measure a current density for these SIS's of  $3,900\ \text{A}/\text{cm}^2$ .

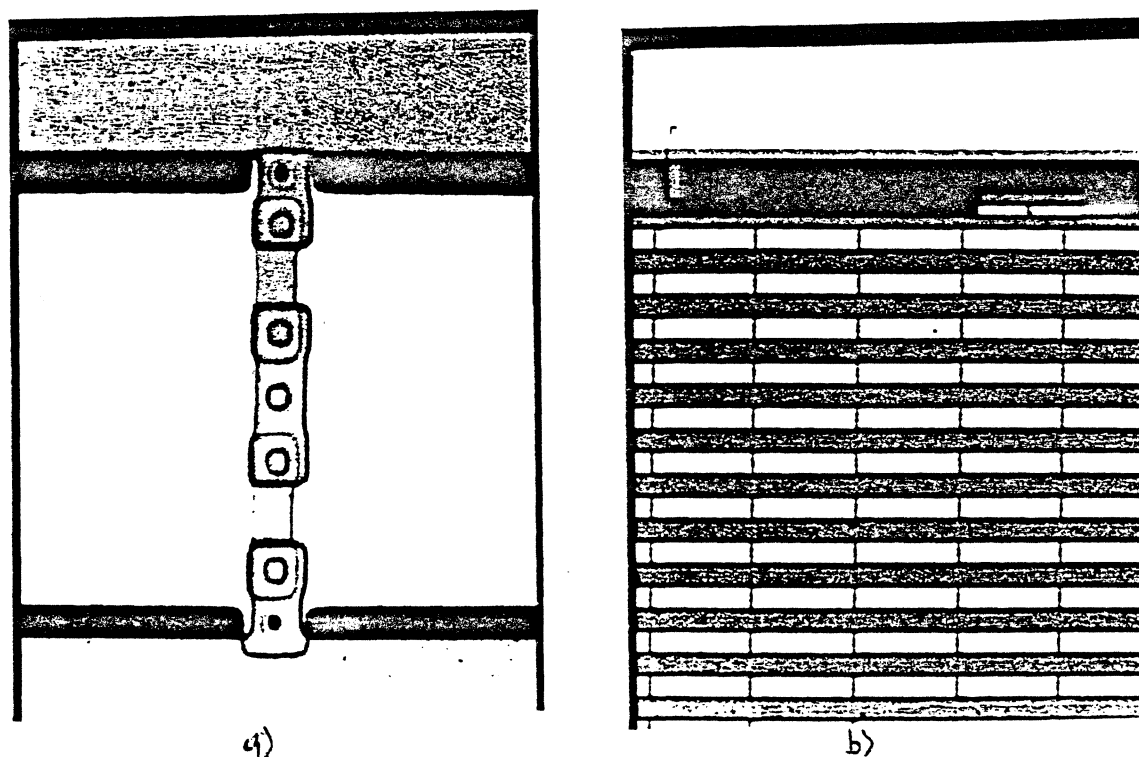

Figure 2. Micrographs showing details of the fabricated array. a) Detail in the vicinity of two junctions. The SIS's are under the small via holes which are topmost and bottommost in the figure. The rest of the structure shows the two shunt resistors, and the vias necessary to contact them. b) Detail showing about 22 rows and 5 columns of the array. A witness junction is seen just above the array.

The rest of the structure seen on the white bias line are the two  $2\ \Omega$  shunt resistors, one for each of the SIS's, and the various via holes needed to make contact to the resistors. Those via holes are  $3 \times 3\ \mu\text{m}$ . The resistors are fabricated on top of the +DC line, and as close to the SIS as possible, to minimize their parasitic series inductance.

### The RF Circuit

In the event that all of the junctions do oscillate in the same phase, we will have strong radiation in a direction perpendicular to the plane of the array. This can be understood by comparing this array with a phased-array antenna. Consider each small part of the array local to each junction as an independent radiator. With no phase difference between elements of the array, the direction in which all the junctions' radiation adds up in phase is perpendicular to the array.

The driving point impedance of the array,  $Z_A$ , should be chosen close to  $2\ \Omega$  so that the shunted Josephson junctions will couple efficiently to it. Of the four different phased-array antennas investigated by Pance and Wengler[9], the Slot Array presented the lowest value of  $Z_A$ . The Slot Array they modelled had a resonant minimum value of  $Z_A$  when horizontal spacing between junctions was close to  $\lambda/2$ .  $\lambda$  is the wavelength of radiation on the slot-line formed by the horizontal dc bias wires connecting adjacent junctions. For the array reported here, that resonant condition is met for a frequency near 170 GHz. This is calculated using the index of refraction  $n = 3.4$  of silicon to characterize the slot-line. Near resonance, the Slot Array had  $Z_A \sim 10\ \Omega$ , but the QJO reported here has somewhat different dimensions than the Slot Array[9].

### Mutual Phase Locking at High Frequencies in the Array

Although all junctions must oscillate at the same frequency because of dc parallel biasing through superconducting wires, this does not constrain them to oscillate in phase. The most important mutual phase-locking mechanism in the arrays presented here is due to the mutual interaction between adjacent junctions at high frequencies. In the vertical dimension, junctions are connected by superconducting metal through a path which is much shorter than any of the wavelengths of interest in this problem. This results in some net series inductance between vertically separated junctions. Both small-signal[10] and large-signal[11] analyses show that an inductive coupling element forces the rf current to flow in series through the adjacent junctions. So within each column of the array, all of the junctions will have the same phase of oscillating current. This does not address the question of the relative phase of adjacent columns.

In the horizontal direction, adjacent junctions are connected by the slot-line transmission line structure formed by the dc bias lines. If the devices are closer together than  $\lambda/2$  on this slot-line, the slot-line could be replaced by a series inductor. In that case, the rf current would flow up through one junction, across the top wire of the slot-line, and then down through the next junction. This is NOT the phase-locking we need. This would result in half the columns in the array being in one phase, and the other half being  $180^\circ$  out of phase.

However, for frequencies high enough so that the length of the slot-line between junctions exceeds  $\lambda/2$ , the equivalent circuit of the slot-line presents a capacitive reactance in series[11,12]. Conceptually, the rf current being pushed into the slot line by one junction goes through a phase-shift of more than  $180^\circ$  before it reaches the next junction. As far as the next junction can tell, it is just as though that current were coming from a junction with  $180^\circ$  phase than is actually the case. The result is that adjacent rows of the array will oscillate in phase, with the net result that every junction in the array is locked in phase, and significant radiation should be developed perpendicular to the plane of the array.

The array presented here shows significant output power at 190 GHz. The slot-line between adjacent junctions exceeds length  $\lambda/2$  for frequencies above approximately 170 GHz. The fact that we see no radiation from the array below that frequency is evidence that our design for mutual phase locking in the horizontal and vertical directions is correct.

Long-range phase-locking between junctions may also be important in this array. In the original proposal[1], the array on the front surface, and metallization on the back surface of the QJO chip were intended to create a resonant cavity in the chip. The idea was that radiation building up in this cavity would be intense enough to injection-lock all the junctions in the array. Since then, it has been determined that with proper design, the array will have a tendency to properly phase-lock simply due to nearest-neighbor interactions[12]. We have designed the arrays so that mutual phase-locking would occur even in the absence of a long-range effect. However, the chip-cavity still exists in our circuit. We need to do experiments where we have a variable cavity behind the QJO so that we can determine how important this is to QJO operation.

### DC Magnetic Flux and Mutual Phase Locking

In addition to high frequency, there are also dc phase-locking mechanisms[10]. These effects are analyzed by Pance for the quasioptical array[13]. Two horizontally adjacent junctions in this array participate in a closed superconducting loop. There will, in general, be dc magnetic flux,  $\Phi$ , in each such loop in the array. For in-phase oscillation of adjacent junctions, it is required that  $\Phi = n\Phi_0$ , where  $n$  is an integer and  $\Phi_0 = 2.07 \times 10^{-15}$  Webers is the quantum of magnetic flux called a fluxon.

The dc magnetic flux,  $\Phi$ , in our array arises from the dc biasing currents. The inductance of each horizontal loop is in the neighborhood of 500 pH. This is calculated using a characteristic impedance of 163  $\Omega$  for the slot-line, as measured for the Slot Array[9]. The critical current of each junction in the array is  $I_C \sim 350 \mu\text{A}$ . Thus, the dc flux condition for in-phase operation of the array is met  $LI_C/\Phi_0 = 85$  times as the bias current of a junction is adjusted through the full range of  $I_C$ . With only a small change of dc bias current, the QJO circuit can relax to any required flux

quantization condition. For this reason, we believe that dc flux quantization places no real constraint on phase-locking in this array.

### Experimental Technique

RF Power is measured using a bolometer operating at 4.2 K which is commercially available from Infrared Laboratories, Inc. The Josephson array and the bolometer are in separate dewars. The QJO dewar layout is shown in fig. 3. The array is mounted on a hyperhemispherical quartz lens to provide a narrower output beam, just as is done with some SIS submillimeter wavelength detectors[14]. The extra quartz windows serve to block infrared radiation from heating the QJO.

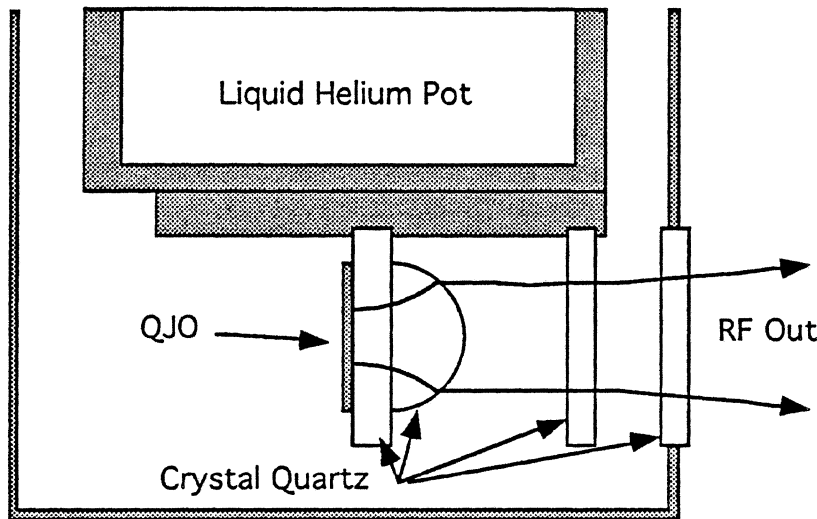

Figure 3. A schematic diagram of the QJO mounted in a dewar.

To detect the power, a lock-in amplifier is used. A chopper wheel interrupting the beam between the oscillator dewar and the bolometer dewar was tried, and then abandoned. In one position of the chopper wheel, the bolometer is seeing the QJO plus the very cold thermal radiation of the inside of the QJO dewar. In the other position of the chopper wheel, the bolometer is illuminated by 295 K room temperature radiation. The bolometer is very broad band, and the thermal difference between 295 K and looking in the QJO dewar corresponds to about  $5 \mu\text{W}$  on the bolometer. It was impossible to detect nW power levels from the QJO with this large thermal signal. To fix this, we removed the physical chopper so the bolometer stares directly into the cold QJO dewar. The bias to the QJO is chopped between 0 mV and the bias voltage under test, and the bolometer signal is detected with a lock-in amplifier locked to this chopped bias. We appear to have sensitivity to about 1 nW power levels using this method.

### Experimental Results

The experimental results for our array are summarized in fig. 4. The peak power detected is  $0.36 \mu\text{W}$  at a bias voltage of 0.37 mV. This power is detected in the bolometer with no corrections made for any losses in coupling between the QJO array and the bolometer. The bias voltage corresponds to a Josephson frequency of 179 GHz.

We measure the frequency of the radiation at the power peak in two different ways. The first is using the witness junction which is fabricated next to the QJO array as shown in fig. 2b. When the array is biased so as to emit its maximum power, the IV curve of the witness junction shows constant voltage Shapiro steps at voltages 0.4 and 0.8 mV, as shown in Fig. 5. These are only produced if the radiation is at 193 GHz.

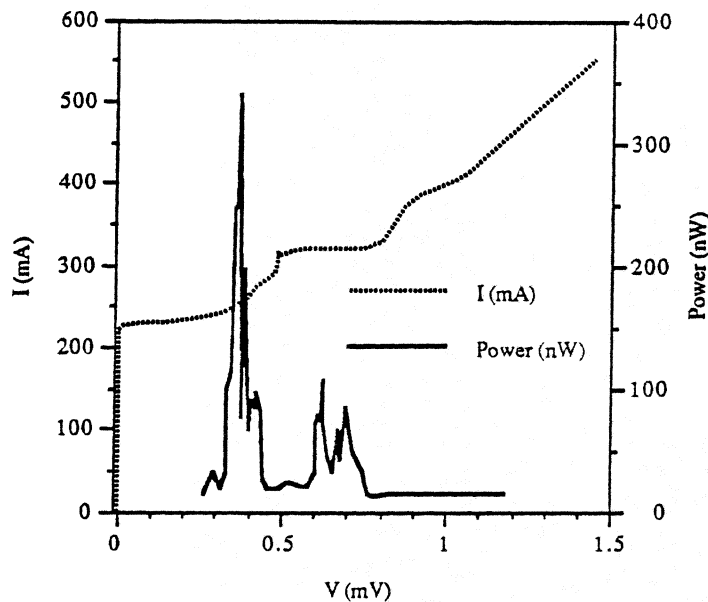

Figure 4. I-V curve and Power-V curve for the array. The tallest power peak occurs at frequency 190 GHz. The secondary peaks near  $V = 0.6$  mV have not had their frequency measured.

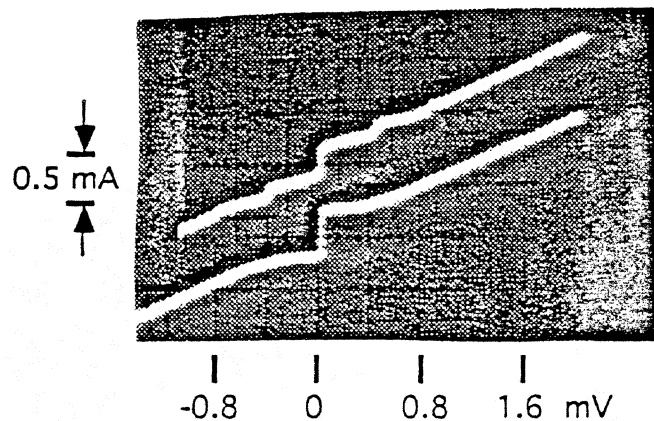

Figure 5. The I-V curve of the witness junction. For the bottom trace, the QJO array is turned off, so the witness junction I-V is RSJ. In the top trace, the QJO array is biased so that its radiation is detected in the external bolometer. The QJO radiation induces Shapiro steps in the witness junction I-V curve..

The second way we measure frequency of the radiation is by inducing standing waves in the radiation traveling between the QJO dewar and the bolometer dewar. This is done with a partially reflecting mesh on a translation stage. As the mesh is moved, the power coupled into the bolometer is modulated. Successive peaks are spaced by 0.8 mm. If this is half a free space wavelength, the radiation is at frequency 187 GHz.

The two measurements of frequency give 193 and 187 GHz for an average of 190 GHz. The apparent Josephson oscillation frequency for the QJO is 179 GHz. The QJO dc voltage is

calculated from an X-Y recorder output which is digitized by hand, and it must be corrected for a parasitic series resistance of about 7 m $\Omega$ . We believe the array is delivering power at about 190 GHz, and that this is the actual Josephson oscillation frequency of the array.

The QJO also has significant radiated power for bias voltages near 0.63 and 0.7 mV. When biased at the power peaks, no Shapiro steps are seen in the witness junction. This suggests, that radiation at these bias voltages is at some frequency other than 190 GHz, where the witness junction is proved to be a sensitive detector of radiation. The most likely situation is that the QJO array is radiating at its Josephson oscillation frequencies which are 305 and 340 GHz for these bias voltages. However, we are concerned that complicated dynamical effects can take place in a large array of coupled Josephson junctions, so we will not yet report for sure that we are seeing radiation at 300 GHz.

### Conclusions

We have demonstrated radiated power from a quasioptical Josephson oscillator (QJO) at 190 GHz. The success of this circuit suggests that the QJO is a good candidate for submillimeter wavelength investigation.

### Acknowledgments

Circuit design and fabrication were supported at HYPRES, Inc. by the Ballistic Missile Defense Organization through the U. S. Army under contract DASG60-93-C-0091. Design work was partially supported at the University of Rochester by the Air Force Office of Scientific Research under grant AFOSR 90-0233. We gratefully acknowledge Professor Dan M. Watson for the loan of the bolometer and advice on measurement techniques.

### References

- [1] M. J. Wengler, A. Pance, B. Liu and R. E. Miller, "Quasioptical Josephson oscillator," *IEEE Trans. Magn.*, vol. 27, pp. 2708-2711, March, 1991.
- [2] C. F. Jou, W. W. Lam, H. Z. Chen, *et al.*, "Millimeter-wave diode-grid frequency doubler," *IEEE Trans. on Microwave Theory and Techniques*, vol. MTT-36, pp. 1507-1514, 1988.
- [3] W. W. Lam, C. F. Jou, H. Z. Chen, *et al.*, "Millimeter-wave diode-grid phase shifters," *IEEE Trans. on Microwave Theory and Techniques*, vol. MTT-36, pp. 902-907, 1988.
- [4] Z. B. Popovic, R. M. W. II, M. Kim and D. B. Rutledge, "A 100-MESFET planar grid oscillator," *IEEE Trans. Microwave Theory and Techniques*, vol. 39, pp. 193-200, February, 1991.
- [5] D. B. Rutledge, Z. B. Popovic, R. M. Weikle, *et al.*, "Quasi-optical power-combining arrays," in *Proc. 1990 IEEE MTT-S International Microwave Symposium Digest*, 1990.
- [6] J. S. Martens, A. Pance, K. Char, *et al.*, "Superconducting Josephson arrays as tunable microwave sources operating at 77 K," *Appl. Phys. Lett.*, vol. 63, pp. 1681-1683, 20 September, 1993.
- [7] P. A. A. Booi and S. P. Benz, "Emission linewidth measurements of two-dimensional array Josephson oscillators," *Appl. Phys. Lett.*, vol. 64, pp. 2163-2165, 18 April, 1994.
- [8] S. Han, B. Bi, W. Zhang and J. E. Lukens, "Demonstration of Josephson Effect Submillimeter Wave Sources with Increased Power," *Appl. Phys. Lett.*, In Press, 1994.

- [9] A. Pance and M. J. Wengler, "Microwave modelling of 2-D active grid antenna arrays," *IEEE Trans. Microwave Theory Tech.*, vol. 41, pp. 20-28, January, 1993.
- [10] A. K. Jain, K. K. Likharev, J. E. Lukens and J. E. Sauvageau, "Mutual phase-locking in Josephson junction arrays," *Physics Reports*, vol. 109, pp. 309-426, 1984.
- [11] B. Liu, "2-D Quasi-Optical Josephson Junction Arrays for THz Oscillators," Ph. D. Thesis, University of Rochester, 1993.
- [12] B. Liu, "Design of a Two-Dimensional Distributed Josephson Junction Array Emitting 190 GHz Free Space Radiation," *Appl. Phys. Lett.*, submitted, 1994.
- [13] A. Pance, "Two-Dimensional Josephson Arrays for Submillimeter Coherent Sources," Ph. D. Thesis, University of Rochester, 1992.
- [14] M. J. Wengler, "Submillimeter wave detection with superconducting tunnel diodes," *Proc. IEEE*, vol. 80, pp. 1810-1826, November, 1992.